



FAULT DIAGNOSIS OF SENSORS IN THE CONTROL SYSTEM OF A STEAM TURBINE

Mariusz Pawlak, PhD., Eng.^{1*}, Janusz Buchta, PhD., Eng.², Andrzej Oziemski, PhD., Eng.³,

^{1,2,3}Lodz University of Technology, Faculty of Electrical, Electronic, Computer and Control Engineering, Bohdana Stefanowskiego 18/22, 90-924 Łódź, Poland, mariusz.pawlak@p.lodz.pl, janusz.buchta@p.lodz.pl, andrzej.oziemski@p.lodz.pl,

*Corresponding author

Information about quoting a paper: Pawlak M., Buchta J., Oziemski A. (2019). Fault diagnosis of sensors in the control system of a steam turbine. Journal of Automation, Electronics and Electrical Engineering JAECE. E-ISSN: 2719-2954. 1(1). 29-36. DOI: <https://doi.org/10.24136/jaeec.2019.004>

Abstract – A diagnostic and control system for a turbine is presented. The influence of the turbine controller on regulation processes in the power system is described. Measured quantities have been characterized and methods for detecting errors have been determined. The paper presents the application of fuzzy neural networks (fuzzy-NNs) for diagnosing sensor faults in the control systems of a steam turbine. The structure of the fuzzy-NN model and the model's method of learning, based on measurement data, are presented. Fuzzy-NNs are used to detect faults procedures. The fuzzy-NN models are created and verified

Key words – diagnostic, turbine, control system, neural networks

INTRODUCTION

The basis of many well-known methods of designing control, diagnostics and forecasting systems, is knowledge of the analytical model of a selected fragment of the technological process of the object, i.e., so-called partial particle models, developed on the basis of the laws of physics and cause-and-effect relationships [1-5]. Unfortunately, the construction of such models is often impossible, or the obtained models are inconvenient to use. On the other hand, the use of simplified and inaccurate models makes it impossible to use the analytical redundancy of the measurement path, which can lead to false diagnoses generated by diagnostic systems [5, 6].

Therefore, in diagnostic systems, "artificial intelligence" models are used: fuzzy models and neural networks or a combination of both techniques, i.e., fuzzy neural networks (fuzzy-NNs) [7-9, 10]. This paper contains an example of such a model, used in a steam turbine control system in order to detect damage in measurement paths.

The turbines referred to in the article are installed on large power units involved in the regulation of the electrical power system. The power blocks currently being built are designed in such a manner as to withstand extremely high steam parameters; so-called supercritical parameters. Due to prevailing economic conditions, the power of such units is 1,000 MW [12]. Such high unit power and very high

parameters of the processed steam (temperature and pressure) forces the use of appropriate diagnostic measures for the power-unit blocks.

Modelling, including systems using "artificial intelligence", is of great importance for the development of modern energy systems. Many models have been developed for conventional energy systems [13, 14] and for renewable energy systems [14, 5].

There are relatively few sources using fuzzy-NN modelling for diagnostic purposes in steam turbines. However, publications on modelling and diagnostics of wind turbines [11] and gas turbines [16] can be found.

This article presents research on a 120-MW power block, because such a block has been made available for testing. The diagnostic system presented, which uses fuzzy-NN systems, is scalable and can be transferred to the power unit working in the supercritical parameter region, e.g., the 900-MW class. This development has already been carried out. It is facilitated by the fact that on modern power units (usually with DCS systems), there is a large quantity of data that can be used to "train" fuzzy-NN models.

Research was conducted to test various model structures and relationships between measurement signals.

I. TURBINE CONTROL SYSTEM

In a power system, the energy unit of the boiler-turbine-engine acts as complex, multidimensional regulation

system. It consists of numerous automatic regulating objects whose task is to maintain particular parameters at certain levels. These objects, which can control numerous parameters, act on the basis of cross coupling, which means that almost every input type interacts with many output types. It is possible to simulate the mutual connections of parameters measured by the energy control block [12]. The choice of a suitable method of modelling depends on the design of the system: at present there is increasing use of artificial intelligence, including artificial neural networks and fuzzy logic systems.

The main task of the power unit, which is involved in the power and frequency regulation of the power system, is proper implementation of turbine set power changes (turbine and generator), which should be fast and, if possible, without delay or deformation, following the set power signal. One of the methods for ensuring the required rate of block load changes is to create an appropriate structure for the load control system, and in particular the turbine regulation system included within it.

The principle of operation of the power-block load system with a leading turbine, is shown in Fig. 1. The power deviation resulting from the comparison of the real power P with the set power P_{set} is sent to the input of the regulator RP, whose output signal Y_{ft} through the electro-hydraulic converter ET of the regulator, controls the movement of the control valves of the turbine V.

The boiler-pressure control unit regulates the fuel inflow by controlling the fuel feeder (FF). The main task of this system is to maintain pressure p_T at the set pressure level. Under these conditions there is an equilibrium between the energy delivered by the fuel to the boiler and the energy output from boiler via steam. When overriding the pressure control unit using the R_p characteristic, the regulated pressure p_T and set pressure p_{set} are compared.

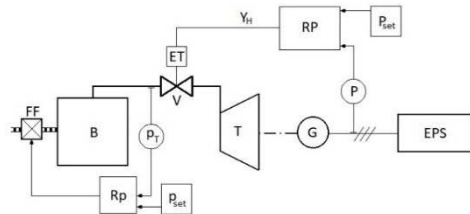

Fig. 1. Load control of the power unit with a leading turbine (B – boiler, T – turbine, G – generator, EPS – electric power system, RP – power regulator, Rp – pressure regulator, FF – fuel feeder, Y_{ft} – control signal, V – valves, ET – electro-hydraulic transducer, P – power, p_T – steam pressure, P_{set} – set point for power and p_{set} – set point for pressure)

Currently, a new type of central regulator has been introduced in the Polish electro-energy system (power system) – LFC (load frequency control). The signal P_w is transmitted to the generating unit. The P_w signal is expressed in the form of a real number, which describes the set power value in MW, according to the ICCP protocol (Inter-Control Center Communication Protocol). In the case of three-way regulation, the Pz_{100} signal, every 15

minutes, carries information about the power baseline. The base power command, like the secondary regulation command, is sent in the form of a real number representing the set base power value in MW.

The LFC regulator module processing the secondary regulation signals operates in real time with a closed feedback loop. It has a PI (proportional-integral) structure and produces a set power signal based on Equation (1).

$$\Delta P = -\beta \cdot ACE - \frac{1}{T} \int ACE \cdot dt \quad (1)$$

where

ΔP is the set power output adjustment [MW],

β is the proportional gain factor [1/MW],

ACE is the regulatory error of the regulated area [MW] and

T is the integration time constant of the integrator [s].

The area error ACE is determined by Equation (2).

$$ACE = \Delta P_i + K \cdot \Delta f \quad (2)$$

where

ΔP_i is the power transmission error [MW],

K is the system constant [MW/Hz] and

Δf is the frequency error [Hz].

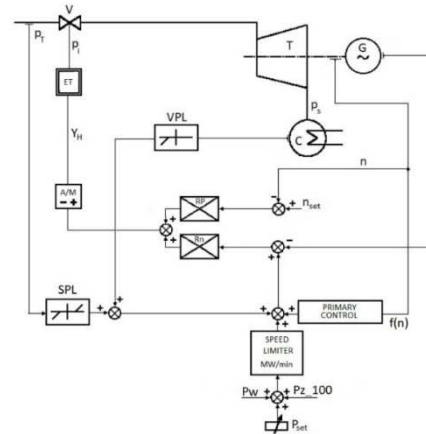

Fig. 2. Block diagram of the turbine power controller

(T – turbine, G – generator, C – condenser, RP – power regulator, Rn – rotation regulator, YH – control signal, V – valves, ET – electro-hydraulic transducer, P – power, p_i – oil pressure, p_T – steam pressure, p_z – absolute vapour pressure, P_{set} – set point for power, n_{set} – set point for rotation, P_w and Pz_{100} – signals from LFC, A/M – manual or automatic control, SPL – steam power limiter and VPL – vapour power limiter)

The requirement for proper operation of the LFC control system is the achievement of a sufficiently fast response time to power variations in the system. This response time cannot exceed 30 s. In addition, the control band must be activated quickly enough. The activation should take, at most, 15 minutes, which means that for the control band, the minimum rate of power changes in the network must be

133 MW/min. This requirement is achieved by splitting the required power over individual generating units, since the rates of change for charging the generating units are then much lower.

II. SENSOR IN TURBINE CONTROL SYSTEM

The power unit is regulated via the turbine control valves (power regulation with a leading turbine). Suitable analogue and binary signals, used for control and protection in the control system, are introduced to the turbine controller (Fig.2).

Measurement paths and control signals are divided into four groups as follows(Fig 3.).

1. Measurements of physical quantities directly from the object, (e.g., power, pressure, steam flow).
2. External signals coming directly from the electro-energy system or directly from the central controller, (e.g., P_w – secondary set power, Pz_{100} – three-way set power and f – voltage frequency in the electro-energy system).
3. Electronic signals transmitted inside the regulator, (e.g., between the main regulator, the ignition switch and the terminal).
4. Auxiliary measurements for the diagnosis of the actuator, (e.g., control oil pressure).

The signals of groups (1) and (2) are determinate, while those of (3) and (4) are stochastic.

The basic output signal from the regulator is the control signal Y_H , which controls the operation of the turbine control valves. The value of this signal changes in the standard range of 0-20mA. The electro-hydraulic transducer ET converts the electrical signal into an oil pressure that controls the position of the turbine's high-pressure servo valves.

The basic quantities regulated in the system are the active power and rotational speed. Active power is supplied to the system through a measurement transducer, which measures the active power of the generator in a three-phase system.

Before synchronizing the generator with the power grid, the rotational speed of the turbine is a controlled parameter. The rotational speed is measured using a toothed wheel and an inductive sensor. The acquired measurement signal, in the form of frequency, is transferred to the appropriate counter input of the controller.

Measurement of the voltage frequency of the power grid is also transferred to the counter input of the controller. Since simultaneous turbine regulators allow the power block to operate via regulation of the electro-energy system, these systems must be adapted to receive the signals that control the system regulation (P_w and Pz_{100}). Information exchange between the turbine control system and the LFC system controller is carried out by means of electronic links, according to the appropriate data exchange protocol.

Other signals introduced into the condensing turbine controller, such as fresh steam pressure, absolute pressure in the con-denser, valve position and fresh steam mass flow, are supplied to the system to ensure good cooperation of the automatic steam pressure regulation system with the condensing turbine power control system.

The measurement paths of these quantities are standard unipolar signals of 4-20 mA.

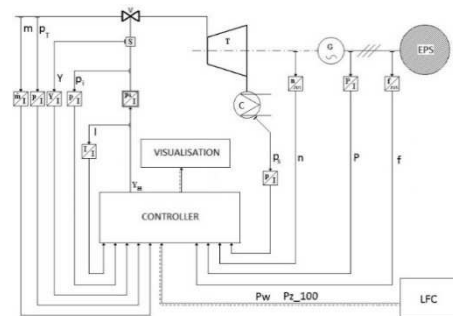

Fig. 3. Measuring tracks in the turbine control system

Table 1. Set of input signals

Symbol	Signal	Unit
P	Electrical power	MW
p_T	Steam pressure	MPa
p_s	Absolute vapour pressure in condenser	%
p_i	Oil pressure	MPa
m	Steam mass flow	t/h
Y	Opening degree of control valves	%
n	Rotation of turbine	min ⁻¹
f	Frequency	Hz
P_w	System set point for power	MW
Pz_{100}	Power set-point signal	MW
I	Current signal	mA

Quantities such as the signal Pz_{100} and the secondary control signal P_w , are transmitted to the system from the outside. The specificity of changes and the types of presented quantities enforce the use of specific methods of detecting damage to their measurement paths. Detection methods must be used here to assess the correctness of the received signal, on the basis of the analysis of one variable only, i.e., methods based on the control of process variables.

The second group of process variables recorded by the controller are local signals received from a given power unit. Here methods based on controlling the connections between process variables can be used, in particular, object models. Determination of residues on the basis of a model is the most robust and reliable method of detection, provided that the model is accurate. The use of models in diagnostics for measurement paths allows parametric damages to be detected over time.

Internal regulator signals, such as connections between the operator's station or the terminal and the communication link with the visualization system, must be controlled online in online mode. Fault detection must adequately reconfigure the controller's hardware structure [5].

III. FUZZY NEURAL NETWORK MODELS FOR DIAGNOSTIC SYSTEMS

MODEL CONSTRUCTION

The construction scheme of the model is presented in

Fig. 4. The fuzzy-NN structure can be divided into two main parts. The first part represents the so-called premise and is responsible for the fragment of the fuzzy rule "if...". It implements the part of the inference mechanism responsible for calculating the level of firing of the rules. The second part represents the so-called conclusion corresponding to the fragment of fuzzy rule "than..." and calculates the output of the model. The "premise" part is identical for all types of network; the difference appears in the "conclusion" part of the model [14].

In Fig. 4, a fuzzy neural network is presented. Layer (D) represents the firing level for individual rules. The firing level of rules is determined as the product of the value of membership functions included in the "premise", while the "conclusion" is consistent with constants. This is the case for a model with two in-puts, one output and nine rules.

This is only a simple example. Nine rules are not enough to build satisfactory models for diagnostic purposes.

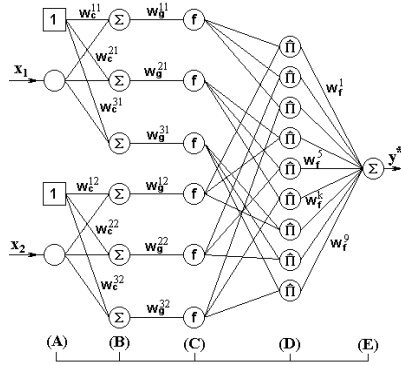

Fig. 4. Implementation of the FNN model with conclusions in the form of constants

The "conclusions" of the presented network are contained in layers (D) and (E), and the weights w^k represent the constants. The network shown in Fig. 4 can be considered as a special case of a Takagi-Sugeno-Kang fuzzy model, in which the "conclusions" of the rules, rather than the equations for linear input variables, contain constants.

LEARNING MODELS

After determining the type of network used, the structure begins to learn based on data collected from the object. The fuzzy-NN learning method can be based on a backward error propagation algorithm. It defines the method of selecting the network weights using gradient optimization methods. The basis of the algorithm is a criterion function. Its purpose is to minimize the weights in the network.

In the considered case, the criterion function takes the following form (3).

After determining the type of network used, the structure begins to learn based on data collected from the object. The fuzzy-NN learning method can be based on a backward error propagation algorithm. It defines the method of selecting the network weights using gradient

optimization methods. The basis of the algorithm is a criterion function. Its purpose is to minimize the weights in the network.

In the considered case, the criterion function takes the following form (3).

$$E(W) = \frac{1}{2}(t - y^*)^2 \quad (3)$$

where

t is the reference value of the output from the model, y^* is the current value of the output from the model and W is the weight of the network.

Weighting updates take place each time after entering the training pair (X, t) , where X is the network input, from the corresponding training set. After determining the criterion function, it should be minimized. This is done by modifying the network weights by a certain amount Δw in proportion to the gradient of the function. For a single weight w , dependencies (4) and (5) can be specified.

$$\Delta w = -\eta \frac{\partial E(W)}{\partial w} \quad (4)$$

$$w(n+1) = w(n) + \Delta w(n) \quad (5)$$

where

η is the learning factor, n is the current moment and $n+1$ is the next moment.

The network learning algorithm will be discussed on the basis of the fuzzy-NN network shown in Fig. 4. In contrast to one-way neural networks, fuzzy-NN networks do not have a homogeneous structure. This entails the need to derive a learning algorithm for each layer separately. The learning algorithm should start from the output layer, i.e., from the modification of the weights w^k (6).

$$\frac{\partial E(W)}{\partial w_f^k} = -(t - y^*) \frac{\partial y^*}{\partial x^E} \frac{dx^E}{dw_f^k} \quad (6)$$

where

w_f^k is the k -th weight of the connections between layers (D) and (E) (Fig. 4) and x^E is the input of layer (E).

To unify the presented equations, it was assumed for layer (E) that $x^E \triangleq y^*$, leading to Equations (7) and (8).

$$\frac{\partial y^*}{\partial x^E} = 1 \quad (7)$$

$$x^E = \sum_k w_f^k y_k^D \Rightarrow \frac{dx^E}{dw_f^k} = y_k^D \quad (8)$$

Equation (6) is simplified to the following form (9).

$$\frac{\partial E(W)}{\partial w_f^k} = -(t - y^*) 1 y_k^D = -\delta y_k^D \quad (9)$$

where

y_k^D is the k-th unit output of layer (D) and $\delta = (t \cdot y^*)$ is the reverse layer difference for layer (D).

On the basis of Equations (4), (5) and (9), the algorithm for modifying a single weight w_f^k can be written as in (10) and (11).

$$\Delta w_f^k(n) = \eta^f \delta y_k^D \quad (10)$$

$$w_f^k(n+1) = \Delta w_f^k(n) + w_f^k(n) \quad (11)$$

where

η^f is the coefficient of learning for weight w_f^k of layer (E) of the network.

After calculating the reverse difference of layer (D), calculations for layer (C) (12) can be performed.

$$\delta_j^C = \sum_k \delta_{k,j}^D \prod_{i \neq j} y_{i,k}^C f'(x_j^C) \quad (12)$$

where

δ_j^C is the j-th reverse layer difference for layer (D) and $\delta_{k,i}^C$ is the reverse difference of the k-th unit of layer (D), which is connected with the j-th unit of layer (C). Hence, for $\delta_{k,i}^C$, $\prod_{i \neq j} y_{i,k}^C$ is the product of the output signals of the layer units (C), up to the k-th layer unit (D), excluding the case $i = j$, $f'(I)$ is the derivative of the internal function of the layer units (C) and x_j^C is the input of the j-th unit of layer (C).

The Gaussian functions $G(x)$ are used for fuzzification of crisp inputs. Thus, the membership functions of the x_j input have the form shown in Equation (13).

$$G(x) = \exp - (w_g^k(x_j + w_c^k))^2 \quad (13)$$

For the Gaussian function, the aforementioned derivative takes the form shown in Equation (14).

$$f'(x_j^C) = 2x_j^C f(x_j^C) \quad (14)$$

The algorithm for modifying the weights w_g is given in Equation (15).

$$w_g^j(n+1) = w_g^j(n) + \eta^g \delta_j^C |w_g^j(n)| y_j^B \quad (15)$$

where

η^g is the learning factor of weight w_g and y_j^B is the output of the j-th unit of layer (C).

The reverse differences of layer units (B) δ_j^B , are calculated in the following manner (16).

$$\delta_j^B = w_g^j \delta_j^C \quad (16)$$

The modification of the weights w_c is described in Equation (17).

$$w_c^j(n+1) = w_c^j(n) + \eta^c \delta_j^B = w_c^j(n) + \eta^c w_g^j(n) \delta_j^C \quad (17)$$

where

η^c is the learning factor for weight w_c .

IV. MODELS FOR POWER UNIT

FUZZY-NN MODELS FOR FAULT DETECTION

The model structure in the form of a fuzzy neural network is organized into the following two steps: the amount, type and location of fuzzy sets for each entry is determined and then a set of rules is defined to form a combination of all sets of fuzzy in-puts [7-11].

In order to carry out diagnostics on measurement systems based on the input data presented in Table 1, the combinations for the development of partial models were selected. Partial models are needed to develop a detection procedure for faults in measurement circuits, and they are used to obtain residuals. On the basis of the analysis of residuals, a fault detection procedure is performed as [18,19].

The models are presented with dependencies as shown in Equations (18) to (23) (the designations are presented in Table 1).

$$\hat{p}_i = f(I) \quad (18)$$

$$\hat{I} = f(P, p_T) \quad (19)$$

$$\hat{m} = f(Y, p_T) \quad (20)$$

$$\hat{P} = f(I, P_{t-1}) \quad (21)$$

$$\hat{P} = f(Y, p_s, p_T) \quad (22)$$

$$\hat{Y} = f(p_i) \quad (23)$$

The purpose of further analysis is to find models with the simplest possible structures that satisfy the assumed requirements. The aim of using simple structures results from the need to minimize learning times and the time required for model output calculations. The presented relationships should also take into account the dynamics of changes in the modelled values.

For functional reasons, combinations of (19) to (23) were selected for modelling, bypassing Equation (18) because this should present a linear relationship in a properly functioning system and it is used for the diagnostics of the actuator. Dependency (23) has been extended to (24) and (25), due to the division of the steam stream into two pipelines supplying steam to the turbine.

$$\hat{Y}_L = f(p_i, Y_p) \quad (24)$$

$$\hat{Y}_p = f(p_i, Y_L) \quad (25)$$

The process of training the models presented with the above relationships, was carried out using the reverse error propagation algorithm. For learning models, a training set was used based on data collected from the real object (turbine on a 120-MW block). The learning factor for the weights was $\eta = 0.001$. For each of the modelled combinations, tests with different initial values were carried out. The weights that were subject to modification aimed to

reach the same value regardless of the starting point. Model verifications were carried out on the basis of a set of data with no training set.

In the following part of the article, selected charts showing the effects of modelling for the developed networks according to the relationship (20) are presented. During the tests, the influence of selected elements on the quality of the obtained models was examined. Different data sets were taken into consideration.

To model the combination according to the relationship (20) for the input variables, five partitions were allocated, i.e., five membership functions for each input. The Gaussian bell function was used as a membership function, according to the dependence described in Equation (13).

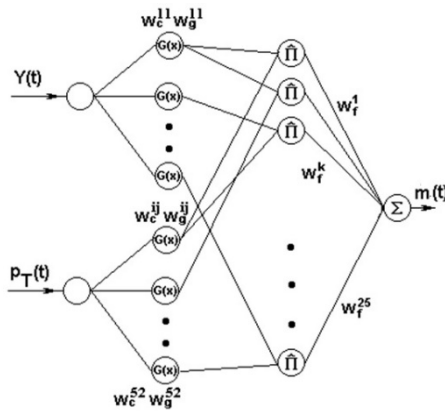

Fig. 5. Structure of the fuzzy-NN model for Equation (22)

The structure shown in Fig. 5. is a development of the model presented in Fig. 6. On the basis of research and analysis, it was found that satisfactory modelling results were obtained with only the five membership functions. Since each input is divided into five fuzzy sets for two inputs, $5 \times 5 = 25$ rules should be specified. The next stage in the construction of the fuzzy-NN model is to find the membership functions. The positions and initial shapes of these functions should be determined. The structure of model (20) consists, among other things, in finding appropriate membership functions for the input quantities of the model, i.e., Y – control of valves and p_T – steam pressure.

For the dependency (13) describing the Gaussian bell function, the coefficients w_g and w_c should be selected. The parameter w_g determines the shape of the function and w_c concerns the location in the space describing the entrance. The input Y has been divided into five fuzzy sets and the range of changes of the signal is $<0,100>\%$. The values of the coefficients are as follows: $w_c = 0.0, 25.0, 50.0, 75.0$ and 100 , and the slope $w_g = 0.075$. The input p_T has become divisible in the same way to cover the entire range of changes in the steam pressure signal, which is in the range $<11,14>$ MPa. The values of the coefficients are as follows: $w_c = 11, 11.75, 12.5, 13.25$ and 14.0 , and the slope of the function $w_g = 0.2$.

To collect the appropriate data sets needed for the models' learning, tests were carried out on the object. The set power for the power unit was subject to changes in the whole range of the regulatory band. Changes of other quantities, such as steam pressure, valve position and steam flow, followed the power changes. The data were recorded to a file with a frequency of 1s. In the graph in Fig. 6, an example printout from one file containing training data, is presented.

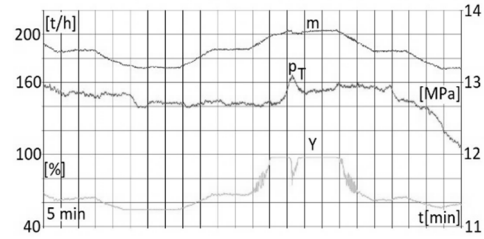

Fig.6. Training data for the model from Equation (20)

The effect of modelling for the data included in the training set (Fig. 6) is shown in Figure 7. The actual value of the steam stream (m [t/h]) and the output value from the model (\hat{m} [t/h]) are shown on one graph. The lower part of the graph shows the residues for the model $r = m - \hat{m}$ and the mean value in the sliding time window from the average residue \bar{r} .

The learning process was completed after about 600 presentations of the training set. For the character-error criterion (26):

$$J = \frac{1}{N} \sum_{i=1}^N \frac{|y_i - \hat{y}_i|}{y_i} \times 100\% \quad (26)$$

where

N is the number of samples in the training set,
 \hat{y}_i is the value calculated from the model and
 y_i is the measured value from the object.

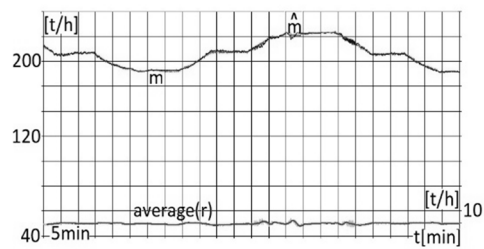

Fig. 7. Verification data for the model, from Equation (23)

Based on Fig. 7, the effects of modelling for the selected combination can be analysed. Two parameters were chosen as the criteria for the quality of modelling: the J -coefficient from Equation (26) and r_{max} – the maximum absolute value of the residue for a given test. The values of these coefficients were as follows: for the graph from Fig. 7, $J = 0.55\%$ and $r_{max} = 3$ t/h. These values were considered

sufficient for industrial purposes for the tested object.

To confirm the results, the model was verified using another set of data with the same parameters but without using the learning process. The set of verification data is presented in Fig. 8. This example set is one of many.

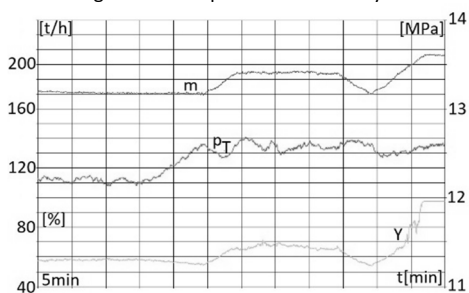

Fig. 8. Verification data for the model from Equation (20)

The range of changes in the steam stream is from 170 t/h to 195 t/h, while the steam pressure changed from 12.2 MPa to 12.7 MPa. These ranges correspond to the rated operating conditions of the control object during system control. The second important condition is that the range of changes was within the range of training data from Fig. 9.

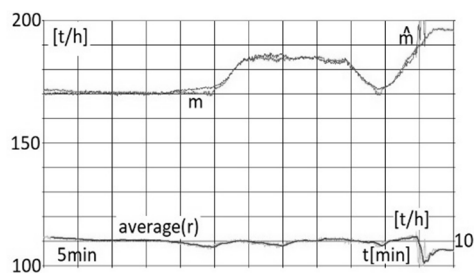

Fig. 9. The modelling effect for data not covered by the training set

The modelling effect is presented in Fig. 9 as before (for Fig. 7.) The mass stream of real and modelled steam and the residual as the difference of these quantities, are shown. The values of these coefficients were as follows: $J = 1.28\%$ and $r_{max} = 10$ t/h. A deterioration in the indicators is shown in the last fragment of the drawing, where one can observe relatively large differences between the model and the actual value. After the analysis, it turned out that the reason was the incorrect operation of the turbine control valves. In Fig. 8. we can observe the maximum control of the signal Y.

Already, at the stage of designing the diagnostic system, the models showed their suitability for detecting malfunctions in the control system.

FAULT ISOLATION

Fault isolation procedures for power, steam pressure, pressure in the condenser and steam mass flow rate sensor faults are based on models (19), (20) and (22). Residuals (27), (28) and (29) are generated.

$$r_1 = I - \hat{I} \tag{27}$$

$$r_2 = m - \hat{m} \tag{28}$$

$$r_3 = P - \hat{P} \tag{29}$$

On the basis of a binary diagnostic matrix (Table 2) developed by an expert, a set of rules necessary to locate faults in an example solution can be developed.

Table 2. Binary diagnostic matrix

	P	p_s	p_T	m
r_1	1	0	1	0
r_2	0	0	1	1
r_3	1	1	1	0

Fault isolation procedures for sensor faults are based on a set of six rules:

- a) If $r_1 = 0$ and $r_2 = 0$ and $r_3 = 0$ then fault-free
- b) If $r_1 = 1$ and $r_2 = 0$ and $r_3 = 1$ then fault P
- c) If $r_1 = 0$ and $r_2 = 1$ and $r_3 = 0$ then fault m
- d) If $r_1 = 1$ and $r_2 = 1$ and $r_3 = 1$ then fault p_T
- e) If $r_1 = 0$ and $r_2 = 0$ and $r_3 = 1$ then fault p_s
- f) Otherwise, unknown state

V. CONCLUSIONS

The presented diagnostic system ensures rapid location of the fault before it adversely affects the course of the adjustment process. Currently, the majority of turbine controllers using microprocessor controllers use costly equipment redundancy in the measurement sensors. The introduction of information based methods of measuring path redundancy increases the reliability of these systems. Simulations and object tests have shown that the measuring methods presented in this paper for the detection and isolation of faults in the measurement paths are well-suited to their functions. The functionality of the entire control system is improved and the costs of implementing the turbine control system are reduced.

Based on the experience gathered in the project and the literature studies carried out, some comments on fuzzy-NN models used for diagnostic purposes may be made.

- These modelling methods are extremely useful for fault detection in non-linear industrial facilities, among other systems.
- Proper preparation of training data largely determines the later correct operation of the fuzzy model.
- It is necessary to provide training data covering the entire work area of the object.
- The right choice of the structure of the model is very important; knowledge about the object and knowledge related to the applied modelling techniques must both be used.
- The number of fuzzy model rules increases sharply with an increase in the number of inputs and the number of fuzzy sets for individual inputs. This limits their application to simple objects.



DIAGNOSTYKA USZKODZEŃ TORÓW POMIAROWYCH W UKŁADZIE STEROWANIA TURBINY PAROWEJ

Przedstawiono system diagnostyki dla układu sterowania turbiny parowej. Opisano procesy regulacji w systemie elektroenergetycznym oraz strukturę układu regulacji turbiny kondensacyjnej w układzie bloku energetycznego. Mierzone wielkości zostały scharakteryzowane wraz z metodami wykrywania uszkodzeń dla poszczególnych wielkości. W pracy przedstawiono zastosowanie rozmytych sieci neuronowych do detekcji uszkodzeń torów pomiarowych. Przedstawiono strukturę modelu rozmytego i metodę uczenia modelu na podstawie danych pomiarowych. Zaprezentowano przykład zastosowania modelu FNN i zweryfikowano jego działanie na podstawie rzeczywistych danych pomiarowych

Słowa kluczowe: diagnostyka, turbina, system sterowania, sieci neuronowe.

BIBLIOGRAPHY

- [1] Guerrero M.J., Peng T., Gui W. (2016) "Open-Switch Fault Diagnosis and Fault Tolerant for Matrix Converter With Finite Control Set-Model Predictive Control", IEEE Transactions on Industrial Electronics, Vol. 63, No.9.
- [2] Schuh M., Zgorzelski M., Lunze J. (2015) "Experimental evaluation of an active fault-tolerant control method". Control Engineering Practice, vol. 43, pp. 1–11.
- [3] Paoli A., Sartini M., Lafortune S. (2011) "Active Fault Tolerant Control of Discrete Event Systems Using Online Diagnostics" Automatica, vol 47, pp. 639-649.
- [4] Calado J.M.F. et al. (2001), "Soft computing approaches to fault diagnosis for dynamic systems" European Journal of Control, vol. 7 (2–3): pp. 248–286.
- [5] Chiang L.H., Russell E.L., Braatz R.D. (2001) "Fault Detection and Diagnosis in Industrial Systems". London, Springer.
- [6] Blanke M., Kinnaert M., Lunze L., Staroswiecki M. (2004) "Diagnosis and Fault-Tolerant Control", Berlin, Springer-Verlag.
- [7] Zhang J., Morris A.J., Martin E.B. (1996) "Robust process fault detection and diagnosis using neuro-fuzzy networks" presented at the 13th Triennial World Congress, San Francisco, USA, 7f-05 pp. 169-174.
- [8] Candau J., de Miguel L.J., Ruiz J.G. (1997) "Controller reconfiguration system using parity equations and fuzzy logic" IFAC Symposium on Fault Detection, Supervision and Safety for Technical Process – SAFEPROCESS'97, Hull, UK, Vol.2, 1258-1263.
- [9] Yang F., Zhang H., Hui G., Wang S. (2012) "Mode-independent fuzzy fault-tolerant variable sampling stabilization of nonlinear networked systems with both time-varying and random delays", Fuzzy Sets Systems, vol. 207, pp. 45–63.
- [10] Li P., Yang G. (2011) "An adaptive fuzzy design for fault-tolerant control of MIMO nonlinear uncertain systems" Journal Control Theory Appl., vol. 9, no. 2, 244–250.
- [11] Blesa J., Rotondo D., Puig V., Nejjari F. (2014), "FDI and FTC of wind turbines using the interval observer approach and virtual actuators/sensors", Control Engineering Practice vol. 24, pp. 138-155.
- [12] Liu X.J., Kong X.B., Hou G.L., Wang J. (2013), "Modeling of a 1000 MW power plant ultra super-critical boiler system using fuzzy-neural network methods", Energy Conversion and Management, vol. 65, pp. 518–527.
- [13] Jonghoon A., Sooyeon Ch. (2017) "Dae Analysis of energy and control efficiencies of fuzzy logic and artificial neural network technologies in the heating energy supply system responding to the changes of user demands", Applied Energy, vol.190, pp.222–231.
- [14] Liu X.J., Lara-Rosanoa F., Chan C.W. (2003) "Neuro-fuzzy network modelling and control of steam pressure in 300MW steam-boiler system", Engineering Applications Artificial Intelligence, vol. 16:431–40.
- [15] Petković D., Cojbašić Z., Nikolić V., Shamshirband S., Kiah L.M., Anuar N.B., Wahid A., Wahab A. (2014) "Adaptive neuro-fuzzy maximal power extraction of wind turbine with continuously variable transmission", Energy, vol. 64, pp. 868-874.
- [16] Hafaifa A., Kouzoul A., Benyounes M.G. (2016) "Gas turbine modeling using adaptive fuzzy neural network approach based on measured data classification Mathematics-in-Industry Case Studies", vol.7:4, 2016.
- [17] Pawlak M. (2016) "Water Level Control System for a Boiler Drum of a Power Boiler Resistant to Measuring Track Damage", Maintenance Problems, vol. 2/2016 (101), pp.135-144.
- [18] Pawlak M. (2018) "Active Fault Tolerant Control System for the Measurement Circuit in a Drum Boiler Feed-Water Control System", Measurement and Control, vol. 51, Issue 1-2, pp. 4-15.